

Incremental Hollow Shaft Encoder RI 58-H

Item No. 2 531 046, Edition 3 160604 Ste1

Page 1/2

HENGSTLER

Hengstler GmbH

Postfach 11 51

D-78554 Aldingen

Tel. 07424 – 890

Fax 07424 – 89470

Introduction

These installation instructions are provided for the connection and starting procedure of your shaft encoder.

For further informations see our Shaft Encoders Catalogue.

Safety and Operating Instructions

- The incremental shaft encoders of the type RI 58-H model series are quality products manufactured in accordance with established electrical engineering standards.
The units have been delivered from the factory in perfect conformance to safety regulations.
To maintain this condition and to ensure trouble-free operation, please observe the technical specifications of this document.
- Installation and mounting may only be performed by an electrotechnical expert!**
- The units may only be operated within the limits specified by the technical data.
- Maximum operating voltages must not be exceeded!**
The units are designed complying with VDE 0160, protection class III.
To prevent dangerous structure-borne currents, the equipment has to be run on safety extra-low voltage (SELV) and must be in an area of equipotential bonding.
- Application: Industrial processes and control systems.
Overvoltage at the connecting terminals must be limited to the values within overvoltage category II.
- The high-quality EMC-specifications are only valid together with standard-type cables and plugs. When using screened cables, the screen must broadly be connected with ground on both ends. Likewise, the voltage-supply cables should entirely be screened. If this is not possible you will have to take appropriate filtering measures.
- Installation environment and wiring are influential on the encoder's EMC:
Thus the installer must secure EMC of the whole facility (device).
- In electrostatically threatened areas please take care for neat ESD-protection of plug and connecting cable during installation work.
- Caution – risk of injury!**
Do not touch the shaft during operation.
Keep long hair or clothing clear from the shaft!
The hollow shaft protruding from the rear of the encoder is slotted.
- For use in class II circuits only

Mechanical data

Mounting	synchro flange ¹⁾
Shaft diameter	hollow shaft 10 mm
	hollow shaft 12 mm
	required dimension of mounting shaft: Ø 10 mm, tolerance g8 (-0.005 ... -0.027 mm) Ø 12 mm, tolerance g8 (-0.006 ... -0.033 mm)
Alignment tolerances	misalignment axial ± 0.4 mm
	parallel 0.4 mm
	angular 1°
Absolute maximum speed	3,000 min ⁻¹
Torque	≤ 2 Ncm (IP 64)
Moment of inertia	ca. 65 gcm ² (shaft 10 mm)
	ca. 95 gcm ² (shaft 12 mm)
Protection class housing/ball bearing	IP 64/64 ²⁾
Operating temperature	-10 ... +70 °C
Storage temperature	-25 ... +85 °C
Vibration performance (IEC 68-2-6)	10 g = 100 m/s ² (10 ... 2000 Hz)
Shock resistance (IEC 68-2-27)	100 g = 1,000 m/s ² (6 ms)
Connection	cable radial
Housing	aluminium
Weight	210 g approx.

¹⁾ use threads M4 for fastening
²⁾ no standing water allowed at the shaft entrance or at the ball bearing

Electrical data

Screening	connected to housing
General design	as per DIN VDE 0160, protection class III, contamination level 2, overvoltage class II
Supply voltage	5 V DC ± 10% or 10 ... 30 V DC (SELV)
Power consumption	40 mA (5 V DC), 30 mA (24 V DC), 60 mA (10 VDC)
Pulse frequency	max. 300 kHz (RS 422) (5 V DC, push-pull) max. 200 kHz (10...30 V DC, push-pull)
Output circuit	RS 422 (T/R), 5 V DC, 10...30 V DC push-pull (K, D), 5 V DC, 10...30 V DC push-pull antivalent (I), 10...30 V DC
Output load	± 30 mA (RS 422, Line driver) ± 10 mA, (5 V DC, push-pull, K) ¹⁾ ± 30 mA (5 V DC, push-pull, D) ± 30 mA (10...30 V DC, push-pull, K, I) ¹⁾
Pulse duty factor	1 : 1
Tolerance	± 25° electrical
Phase shift	90° (distance from Channel A to B is at least 0,45 µs, at 300 kHz)
Output signals	A, B, N or AĀ, BĀ, NĀ
Pulse rise time	≤ 100 ns (RS 422), ≤ 250 ns (push-pull)
Pulse shape	rectangular
Alarm output	Open Collector, NPN (5 mA, 24 V max with U _i =5VDC; 5 mA, 32 V max. with U _i =10...30 VDC)

¹⁾ short circuit and overload proof over the whole temperature range

Connection diagram

		Output circuit			
Colour (TPE)	Colour (PVC)	RS 422 (T) + Sense	RS 422 (R) + Alarm	Push-pull (K)	Push-pull complem. (I)
brown	white	Channel A	Channel A	Channel A	Channel A
green	white/brown	Channel Ā	Channel Ā		Channel Ā
grey	green	Channel B	Channel B	Channel B	Channel B
pink	green/brown	Channel B̄	Channel B̄		Channel B̄
red	yellow	Channel N	Channel N	Channel N	Channel N
black	yellow/brown	Channel N̄	Channel N̄		Channel N̄
violet (white) ¹⁾ yellow/black		Sense GND	Alarm	Alarm	Alarm
blue	yellow/red	Sense V _{CC}	Sense V _{CC}		Sense V _{CC}
brown/green red		5VDC	5/10...30VDC	5/10...30VDC	10...30VDC
white/green	black	GND	GND	GND	GND
Screen ¹⁾	Screen ¹⁾	Screen ¹⁾	Screen ¹⁾	Screen ¹⁾	Screen ¹⁾

¹⁾ connected to encoder housing
²⁾ white for Sense (T)

Ordering data (see identification plate)

H hollow shaft	Supply voltage A 5 VDC E 10 ... 30 VDC	Type of flange S synchro flange	Shaft diameter 2 10 mm 7 12 mm
Resolution 1 ... 5000	Protection class 3 IP 64	Output K push-pull R RS 422 + Alarm T RS 422 + Sense I push-pull complementary D push-pull 5 V, 30 mA	Type of connection B cable PVC, radial F cable TPE, radial

* Special types are additionally marked by an ordering code -S. In this case customer specifications are to be applied. If you don't know these please call us for the specifications, indicating the encoder ordering code.

Incremental Hollow Shaft Encoder RI 58-H

Page 2/2

Installation instructions

- All installation work must be performed in accordance with the relevant safety regulations!
- All equipment involved must be electrically disconnected during installation work!
Please ensure that current cannot be applied to this equipment unintentionally during installation.

Preparing for mechanical installation

Before starting the installation, the drive of the *host device* must be prepared to pick up the encoder.

Due to the wide range of drive constructions and installation requirements, only general instructions can be provided; please also refer to the dimensioned drawings of the different encoder versions.

When using an adapter between drive and encoder, the adapter must be designed in a manner that

- the encoder can be mounted safely without being exposed to vibration,
- the encoder can be mounted on the drive before the "B"-side of the drive shaft is secured to the encoder's hollow shaft,
- radial, axial and angular misalignments remain within the specified limits.

Note

- The durability of the integrated coupling largely depends on proper mounting! The coupling must be attached in its neutral position!
Forced compression or extension and/or compensation of an excessive angular or shaft misalignment shorten service life!
- The encoder housing is attached flexibly to the mounting flange.
Subjection to external forces may result in pulse output to the data lines!
Therefore no external forces should be applied to the encoder housing!
- Ensure that the clamping jaw of the hollow shaft is loosened by inserting the drive shaft into the hollow shaft (the clamping jaw is located on the synchro flange side of the encoder).
The shaft must slide easily into the hollow shaft!
Do not use force or try to insert the shaft by hammering on one end!
This would damage the encoder.
- If the shaft cannot be inserted, please check the shaft diameter and/or open the clamping jaw.

Loosening the clamping jaw

(please refer to the following figure and its key)

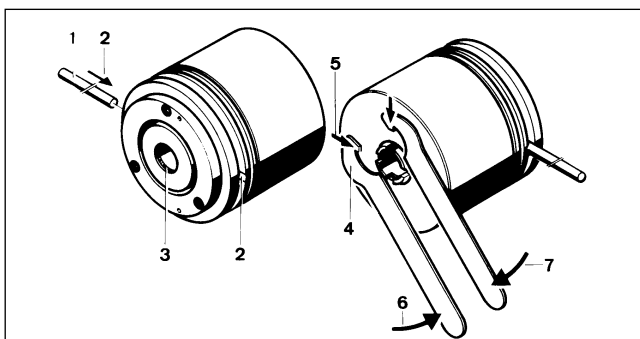

Fig.: Loosening the clamping jaw

Instructions for loosening the clamping jaw

- Insert the retention pin (1) in one of the two holes (2).
- Press the retention pin lightly into the hole and rotate the hollow shaft. After a maximum rotation angle of 180° the retention pin will engage.
- Hold the pin in this position.
- Open the clamping jaw by inserting the hooked wrench (4) in one of the slots of the hollow shaft (5) and rotating the shaft counterclockwise by approx. 1 revolution (6).
This loosens the clamping jaw completely.
- Remove the wrench and the pin.

Mechanical installation instructions

The shaft encoder can be attached to the drive unit in two ways:

- by means of three screws to be screwed into the front end of the encoder
- by means of three clamping eccentrics.

The preparations required for mounting of the drive and the encoder must be complete now.

- Put the encoder on the drive by inserting the actuating end of the drive shaft into the hollow shaft.
- Attach the encoder to the drive by means of the screws resp. the clamping eccentrics.

Securing the drive shaft in the hollow shaft (please refer to the figure)

- Insert the retention pin (1) in one of the two holes (2).
- Press the retention pin lightly into the hole and rotate the hollow shaft. After a maximum rotation angle of 180° the retention pin will engage.
- Hold the pin in this position.
- Tighten the clamping jaw by inserting the hooked wrench (4) in one of the slots of the hollow shaft (5) and rotate the shaft clockwise (7).
This tightens the clamping jaw and clamps the drive shaft.
- Tighten the clamping jaw but moderately:
 - max. tightening torque for shaft 10 mm = 2,5 Nm
 - max. tightening torque for shaft 12 mm = 3,0 Nm.

- Remove the wrench and the pin.

Ensure that no external forces take effect on the encoder during assembly or operation!

Key to the figure

- 1 Retention pin (included)
- 2 Holes for retention pin
- 3 Clamping jaw of the hollow shaft
- 4 Hooked wrench
- 5 Slots in hollow shaft
(for hooked wrench)
- 6 Sense of rotation for loosening the clamping jaw
- 7 Sense of rotation for tightening the clamping jaw



Shaft rotates during operation!